



**3 GHz SMA LATCHING S.P.9 T. SWITCH**

OPTIONS : /SELF CUT-OFF /AUTO RESET /BCD DECODER /SUPP.DIODES

**R F CHARACTERISTICS**

NUMBER OF WAYS : 9  
 FREQUENCY RANGE : 0 - 3 GHz  
 IMPEDANCE : 50 Ohms

FREQUENCY (GHz)	0 - 3
V.S.W.R <=	1.20
INSERT. LOSS <=	0.20 dB
ISOLATION >=	80 dB
AVER. POWER (*)	240 W

**ELECTRICAL CHARACTERISTICS**

ACTUATOR : LATCHING  
 NOMINAL CURRENT AT 25° C (±10%) : 1280 mA  
 ACTUATOR VOLTAGE (Vcc) : 12V (10.2 to 13V) / NEGATIVE COMMON  
 TERMINALS : 25 pins D-SUB male connector  
 SELF CUT-OFF TIME : 40 ms < CT < 120 ms  
 BCD INPUTS (E) - High level : 3.5 to 5.5V / 800µA at 5V  
 - Low level : 0 to 1.5V / 20µA at 0.8V

**MECHANICAL CHARACTERISTICS**

CONNECTORS : SMA female per MIL-C 39012  
 LIFE : 2.000.000 cycles per position  
 SWITCHING TIME (nominal voltage;25° C) : < 50 ms  
 CONSTRUCTION : splashproof  
 WEIGHT : < 360 g

**ENVIRONMENTAL CHARACTERISTICS**

OPERATING TEMPERATURE RANGE (°C) : -40 , +85  
 STORAGE TEMPERATURE RANGE (°C) : -55 , +85

(\* : average power at 25° C per RF path)

This information is given as an indication. In the continual goal to improve our products, we reserve the right to make any modifications judged necessary

4112-9212

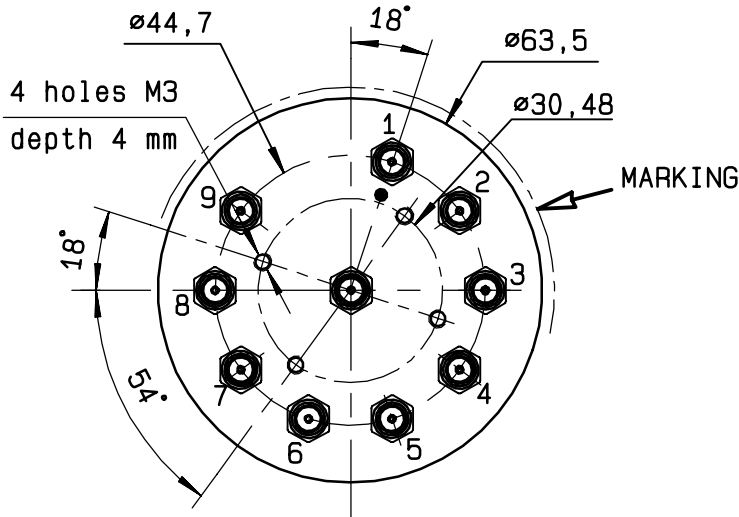

BCD TRUTH TABLE				
E4	E3	E2	E1	RF continuity
0	0	0	0	ALL PORTS OPEN (FORCED RESET)
0	0	0	1	IN ↔ 1
0	0	1	0	IN ↔ 2
0	0	1	1	IN ↔ 3
0	1	0	0	IN ↔ 4
0	1	0	1	IN ↔ 5
0	1	1	0	IN ↔ 6
0	1	1	1	IN ↔ 7
1	0	0	0	IN ↔ 8
1	0	0	1	IN ↔ 9

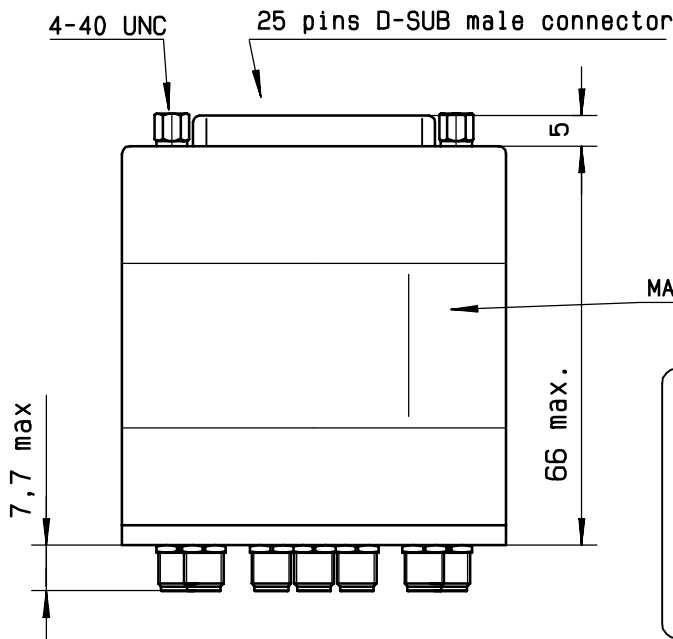

MARKING TOP VIEW (TERMINALS)

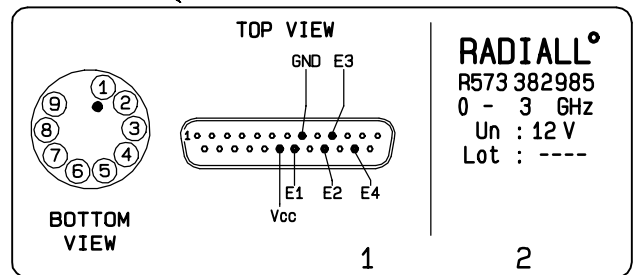

**RADIALL<sup>o</sup>**  
 R573 382985  
 0 - 3 GHz  
 Un : 12 V  
 Lot : ----

**SCHEMATIC DIAGRAM**

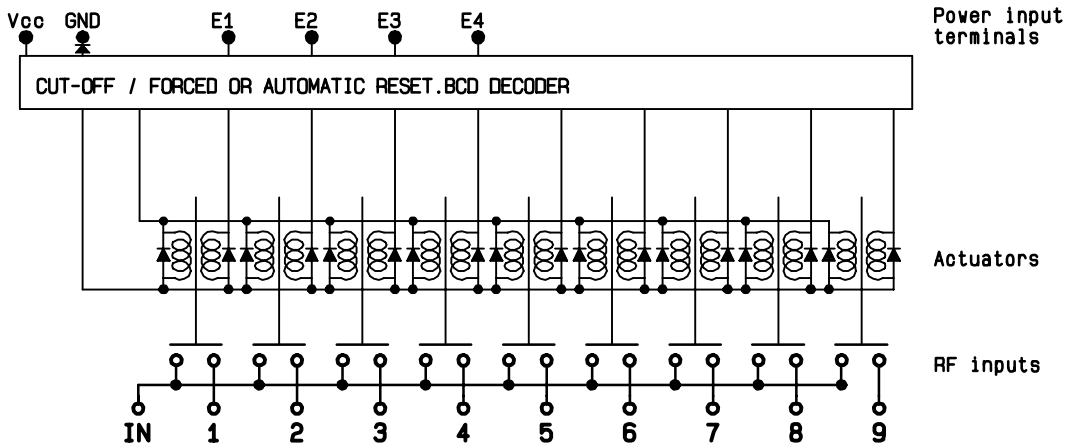

This information is given as an indication. In the continual goal to improve our products, we reserve the right to make any modifications judged necessary  
 4113-9212